



Standard Test Method for Strength Properties of Double Lap Shear Adhesive Joints by Tension Loading¹

This standard is issued under the fixed designation D3528; the number immediately following the designation indicates the year of original adoption or, in the case of revision, the year of last revision. A number in parentheses indicates the year of last reapproval. A superscript epsilon (ϵ) indicates an editorial change since the last revision or reapproval.

INTRODUCTION

The accuracy of the results of strength tests of adhesive bonds will depend on the conditions under which the bonding process is carried out. Unless otherwise agreed upon between the manufacturer and the purchaser, the bonding conditions should be prescribed by the manufacturer of the adhesive. In order to ensure that complete information is available to the individual conducting the tests, the manufacturer of the adhesive should furnish numerical values and other specific information for each of the following variables:

- (1) Surface preparation
- (2) Mixing directions
- (3) Adhesive application
- (4) Assembly conditions
- (5) Curing conditions
- (6) Testing conditions

A range may be prescribed for any variable by the manufacturer of the adhesive if it can be assumed by the test operator that any arbitrarily chosen value within such a range or any combination of such values for several variables will be acceptable to both the manufacturer and the purchaser of the adhesive.

1. Scope

1.1 This test method covers the determination of the tensile shear strengths of adhesives for bonding metals when tested in an essentially peel-free standard specimen that develops adhesive stress distribution representative of that developed in a typical low-peel production-type structural joint. The reproducibility of the strengths achieved are directly related to conformance with specified conditions of preparation and testing.

1.2 The values stated in SI units are to be regarded as the standard. The values given in parentheses are for information only.

1.3 *This standard does not purport to address all of the safety concerns, if any, associated with its use. It is the responsibility of the user of this standard to establish appropriate safety and health practices and determine the applicability of regulatory limitations prior to use.*

2. Referenced Documents

2.1 *ASTM Standards:*²

- [A167 Specification for Stainless and Heat-Resisting Chromium-Nickel Steel Plate, Sheet, and Strip \(Withdrawn 2014\)](#)³
- [B36/B36M Specification for Brass Plate, Sheet, Strip, and Rolled Bar](#)
- [B152/B152M Specification for Copper Sheet, Strip, Plate, and Rolled Bar](#)
- [B209 Specification for Aluminum and Aluminum-Alloy Sheet and Plate](#)
- [B265 Specification for Titanium and Titanium Alloy Strip, Sheet, and Plate](#)
- [D618 Practice for Conditioning Plastics for Testing](#)
- [D907 Terminology of Adhesives](#)
- [E4 Practices for Force Verification of Testing Machines](#)
- [E122 Practice for Calculating Sample Size to Estimate, With](#)

¹ This test method is under the jurisdiction of ASTM Committee D14 on Adhesives and is the direct responsibility of Subcommittee D14.80 on Metal Bonding Adhesives

Current edition approved May 1, 2016. Published May 2016. Originally approved in 1976. Last previous edition approved in 2008 as D3528 – 96 (2008). DOI: 10.1520/D3528-96R16.

² For referenced ASTM standards, visit the ASTM website, www.astm.org, or contact ASTM Customer Service at service@astm.org. For *Annual Book of ASTM Standards* volume information, refer to the standard's Document Summary page on the ASTM website.

³ The last approved version of this historical standard is referenced on www.astm.org.

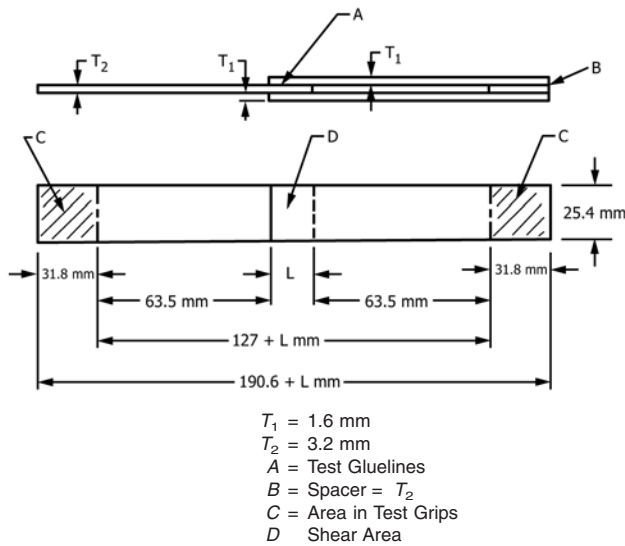

FIG. 1 Form and Dimensions of Type A Specimens

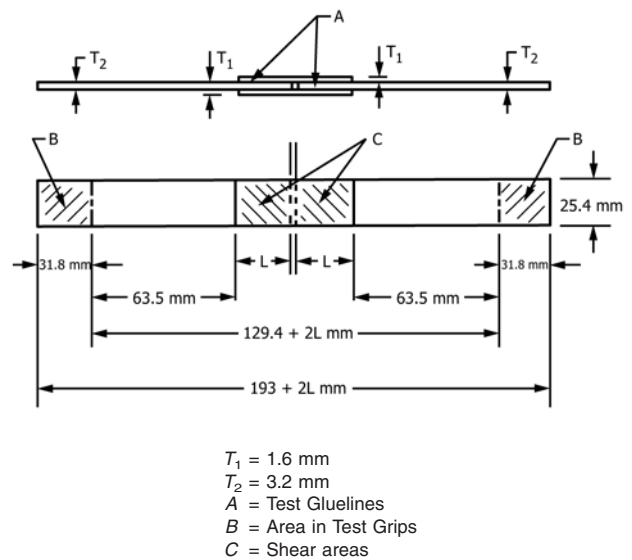

FIG. 2 Form and Dimensions of Type B Specimen

Specified Precision, the Average for a Characteristic of a Lot or Process

E171 Practice for Conditioning and Testing Flexible Barrier Packaging

3. Terminology

3.1 *Definitions*—Many terms in this test method are defined in Terminology D907.

4. Significance and Use

4.1 This test method is designed to produce shear property data for the process control and specification of adhesives. This test method may also be useful for research and development of adhesives.

4.2 Lap shear properties vary with specimen configuration preparation, speed, and environment of testing. Consequently, where precise comparative results are desired, these factors must be carefully controlled and reported.

5. Apparatus

5.1 *Testing Machine*, conforming to the requirements of Practices E4. The testing machine should be so selected that the breaking load of the specimens falls between 15 and 85 % of the full-scale capacity. The machine should be capable of maintaining a rate of loading of 8.27 to 9.65 MPa (1200 to 1400 psi)/min, or if the rate is dependent on crosshead motion, the machine should be set to approach the rate of loading. It should be provided with a suitable pair of self-aligning grips to hold the specimen. The grips and attachments should be so constructed that they will move into alignment with the test specimen as soon as the load is applied, so that the long axis of the test specimen will coincide with the direction of the applied pull through the center line of the grip assembly.

6. Test Specimen

6.1 The test specimens should conform to one of the alternative types as dimensioned and shown in Fig. 1 or Fig. 2.

Cut the specimens from the appropriate test panels that have been prepared as prescribed in Section 7. For aluminum-alloy specimens the recommended thickness of the sheet is $3.24 \pm 0.125 \text{ mm}$ ($0.125 \pm 0.005 \text{ in.}$). The recommended test overlap length (L) for most metals, with adherends of the prescribed metal thickness and arranged as shown in Figs. 1 and 2, is $12.7 \pm 0.25 \text{ mm}$ ($0.5 \pm 0.01 \text{ in.}$).

NOTE 1—Since it is undesirable to exceed the yield point of the metal in tension during test, the permissible length of overlap in the specimen will vary with the thickness and type of metal and on the general level of strength of the adhesive being investigated. The maximum permissible length may be computed from the following relationship:

$$L = \frac{F_{ty} t_1}{\tau} \quad \text{and} \quad L = \frac{F_{ty} t_2}{2}$$

where:

- L = length of overlap, in., (Figs. 1 and 2),
- t_1 = thickness of doubler, in., (Figs. 1 and 2),
- t_2 = thickness of adherend in., (Figs. 1 and 2),
- F_{ty} = yield point of adherend (or stress at proportional limit), psi, and
- τ = 150 % of the estimated average shear strength of the adhesive bond, psi.

NOTE 2—Variations in adherend thickness, and of the length of the overlap, normally influence the test values and make direct comparison of test data questionable. Therefore, it is preferable for the comparative or specification tests, to standardize on the typical specimen configuration shown with appropriate adherend gages as computed in accordance with Note 1. When specimens incorporating special lap lengths are developed for specific studies, the adherend gage and geometry, once established, should not be altered.

6.2 The following grades of metals are recommended for the test specimens:

Brass	Specification B36/B36M, CDA 268
Copper	Specification B152/B152M, CDA 110
Aluminum	Specification B209, Alloy 2024, T3 Temper
Corrosion-resisting steel	Specification A167, Type 302, 2B Finish
Titanium	Specification B265, Grade 3

6.3 The minimum sample size necessary to develop typical or design values for a given joint geometry should be specified on the test request in accordance with the principles presented